

* V means 1500V module

HT60-156M HT60-156M(V) **BLACK**

POWER OUTPUT

**300W / 305W
310W / 315W / 320W**

BLACK MODULE



- Module Efficiency: 19.67%
- No. of Cells: 60 (6 × 10)
- Weight: 18.5kg
- Dimensions: 1640mm×992mm×35mm

Monocrystalline
156.75 × 156.75mm



Shanghai Aerospace Automobile
Electromechanical Co., Ltd.
website: www.ht-saae.com



Factory:
Lianyungang ShenZhou New Energy Co., Ltd.
Turkey HT Solar Energy Joint Stock Company

PID
PID Resistant



Designed for high voltage systems of up to 1500 VDC, increasing the string length of solar systems and saving on BoS costs



Advanced surface treatment, lower surface reflection and 5BB cell design can reduce the series resistance and improve the module efficiency

1000 Pa

Certified to withstand dynamic mechanical load 1000 Pascal



Microcrack resistant
Triple EL tested of high quality control.



Entire module certified to withstand extreme wind (2400 Pa) and snow loads (5400 Pa)



Ammonia / Salt Mist
Corrosion resistant

2%

All the modules are sorted and packaged by amperage, reducing mismatch losses and maximizing system output.

Comprehensive and first-rate certification system

IEC61215: 2016, IEC61730: 2016 Latest Standard
ISO9001, ISO14001 and OHSAS18001,
meeting the highest international standards
Strict quality control



IEC 61215
IEC 61730
Regular Production
Surveillance
www.tuv.com

* Copyright@2018V3 Specifications are subject to change without further notification

Engineering Drawing

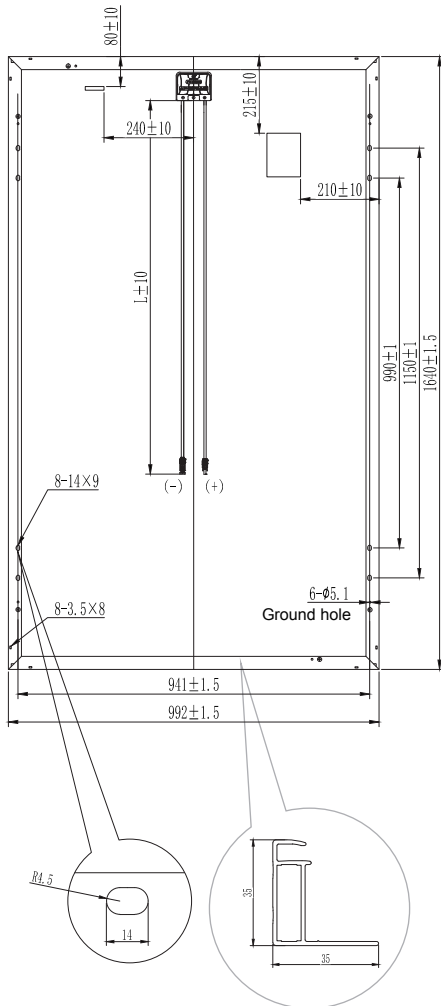

Electrical Characteristics

Module	HT60-156M / HT60-156M(V)				
Maximum Power at STC(Pmax)	300W	305W	310W	315W	320W
Open-Circuit Voltage(Voc)	39.9V	40.1V	40.3V	40.5V	40.6V
Short-Circuit Current(Isc)	9.71A	9.78A	9.85A	9.92A	10.36A
Optimum Operating Voltage (Vmp)	32.8V	33.2V	33.6V	34.0V	33.7V
Optimum Operating Current(Imp)	9.16A	9.21A	9.25A	9.29A	9.51A
Module Efficiency	18.4%	18.8%	19.1%	19.4%	19.67%
Power Tolerance	0 ~ +5W				
Maximum System Voltage	1000V / 1500V DC(IEC)				
Maximum Series Fuse Rating	15A				
Operating Temperature	-40 °C to +85 °C				

*STC: Irradiance 1000W/m², module temperature 25, AM=1.5
Optional black frame or white frame module according to customer requirements

NOCT

Module	HT60-156M / HT60-156M(V)				
Maximum Power	221W	225W	229W	232W	237W
Open Circuit Voltage (Voc)	37.2V	37.4V	37.6V	37.8V	38.4V
Short Circuit Current (Isc)	7.84A	7.90A	7.96A	8.01A	8.37A
Maximum Power Voltage (Vmp)	30.5V	30.9V	31.3V	31.7V	31.8V
Maximum Circuit Current (Imp)	7.24A	7.27A	7.31A	7.33A	7.45A
NOCT	45°C ± 2°C				

*NOCT: Irradiance 800W/m², ambient temperature 20 °C, wind speed 1 m/s

Mechanical Characteristics

Solar Cells	Monocrystalline 156.75 × 156.75mm
No. of Cells	60 (6 × 10)
Dimensions	1640mm × 992mm × 35mm
Weight	18.5kg
Front Glass	High transmission tempered glass
Frame	Anodized aluminium alloy
Junction Box	IP67
Cable	4mm ² (IEC)
Connectors	MC+ / MC- Compatible
Packaging Configuration	30pcs / box, 840pcs / 40'HQ Container

Temperature Characteristics

Temperature Coefficient of Pmax	γ (Pm)	-0.39%/K
Temperature Coefficient of Voc	β (Voc)	-0.29%/K
Temperature Coefficient of Isc	α (Isc)	0.049%/K

I-V Curves

Current-Voltage & Power-Voltage Curve

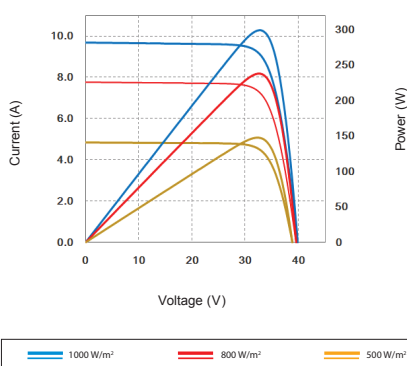

Warranty

10-year product warranty
25-year warranty on power output
Specific information is referred to the product quality guarantee

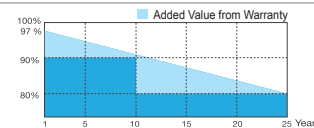

Information Box